

Fusion 600 is a high-speed, multisensor measurement system with 3D capability that combines an exceptional large field-of-view (LFOV) optical system with multisensor flexibility to form a uniquely productive metrology system. Fusion 600 offers:

- **Telecentric Large Field Optics** – Dual optical paths – low mag with 100 mm viewing area and high mag for small feature measurement and autofocus, fully telecentric for image accuracy.
- **Multisensor Versatility** – Optional touch probe, TeleStar® Plus TTL Laser, Rainbow Probe™, continuous contact scanning probe, and 4th and 5th axis rotary indexers. All sensors are placed precisely on the optical centerline by the rotational deployment mechanism allowing for use over the full stage travel.
- **ZONE3® Productivity** – CAD-based metrology software, with integral AutoID and FeatureExtractor functions, ideal for large field of view (LFOV) optics.

Innovative Large Field-of-View (LFOV) Multisensor Measuring System with an Expansive Measuring Volume

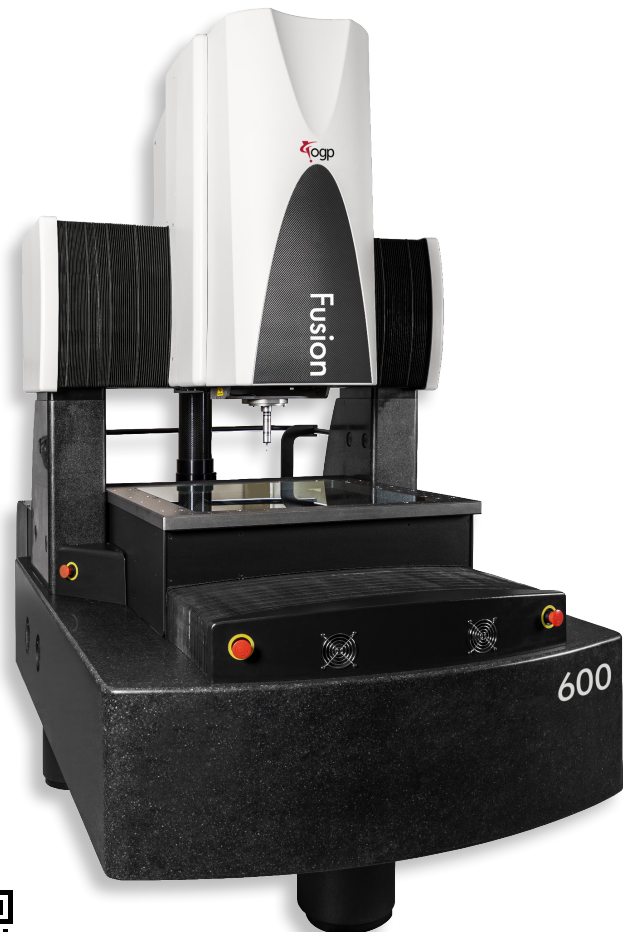

Shown with optional on-axis scanning probe.

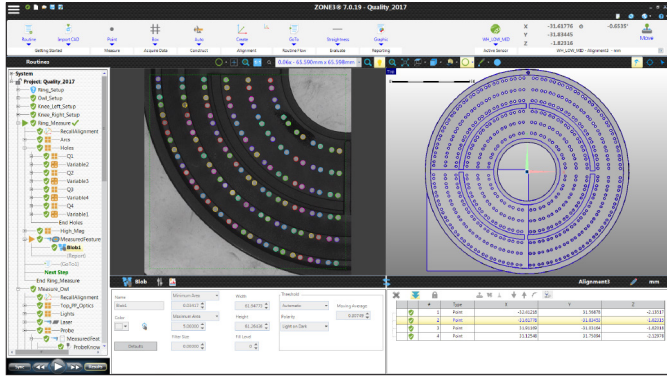

ZONE3 uses innovative features to automatically generate measurement routines resulting in faster programming and run times. Parallel processing combined with intelligent routine optimization can be used to measure as many features as can be seen simultaneously.

Fusion™ 600

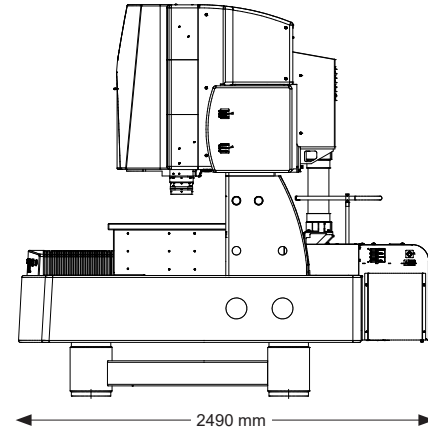
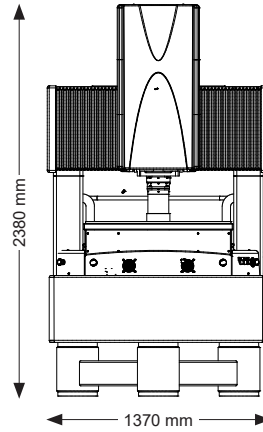

System Weight: 4910 kg
Shipping Weight: 6100 kg

Optics	Low Mag	High Mag
Camera	4MP digital, monochrome metrology camera	5MP digital, monochrome metrology camera
Field of View	70 x 70 mm	14 x 14 mm
Depth of Field	75 mm	2 mm
Working Distance	185 mm	185 mm
Accessories	Laser Range Finder system for optimal Z-focus positioning	

System	Standard	Optional
XYZ Travel	540 x 500 x 300 mm	
XYZ Measuring Range (max)	610 x 570 x 300 mm	
XYZ Scale Resolution	0.1 µm	0.05 µm
Drive System	XY: Liquid cooled linear motor; Z: DC servo with pneumatic counterbalance	
Worktable	Hardcoat anodized, with fixture holes, removable stage glass, 100 kg recommended max payload	
Rotary Axis		Miniature Servo Rotary (MSR™), MicroTheta Rotary (MTR™), Heavy Duty Rotary (HDR), High Precision Rotary (HPR™), Dual Rotary
Transport Velocity / Acceleration (max)	Velocity: XY Vector = 300 mm/sec, Acceleration: XY Vector = 500 mm/sec ²	
Illumination	All LED substage profile, coaxial surface, and programmable ring light with 2 rings and 8 sectors	
Sensor Deployment Mechanism	On-axis, air-actuated rotational deployment mechanism (RDM)	
Deployable Non-Contact Sensors		RP-1500 Rainbow Probe
Deployable Tactile Sensors		TP20 or TP200 Touch Probe SP25 Scanning Probe
Through-the-Lens Lasers		TeleStar® Plus Interferometric TTL Laser
Software	<ul style="list-style-type: none"> • ZONE3® Express 3D Metrology Software • QVI® Portal 	Metrology Software: ZONE3 Prime, ZONE3 Pro Productivity Software: MeasureFit® Plus, SmartFit® 3D, OGP® EVOLVE® Suite (Design, EVOLVE SPC, Manufacturing, SmartProfile®) Offline Software: ZONE3
System Controller	Windows® based, with up-to-date processor and networking/communication ports	
Controller Options	24" flat panel LCD monitor, keyboard, 3-button mouse, ergonomic sit/stand operator workstation	Dual 24" flat panel LCD monitors
Power Requirements	200 - 240 VAC, 50/60 Hz, 1 phase, 1550 W	
Compressed Air Requirements	Air supply pressure: 0.6 - 1.0 MPa; Minimum Flow capacity: 7.5 NI/min; Air quality ISO 8573-1:2010 Class 4.3.4 or better	Air dryer kit
Safe Operating Environment	15-30° C, non-condensing	
Rated Environment	Temperature 18-22 °C, stable to ±1 °C; max rate of change 1 °C / hour, max vertical gradient of 1 °C / meter; 30-80% humidity; vibration <0.001g below 15 Hz	
XY Area Accuracy	$E_2 = (1.8 + 4L/1000) \mu\text{m}$	
Z Linear Accuracy		$E_z = (2.0 + 5L/1000) \mu\text{m}$ (requires optional Touch Probe or TeleStar Plus TTL Laser)

Accuracy is evaluated with a QVI verification procedure where "L" is measured length in millimeters. Specifications apply within the rated environment. Accuracy specifications are verified with the imaging sensor unless otherwise specified. Standard optical specifications apply at the maximum optical magnification of the standard configuration. XY Accuracy applies with an evenly distributed load up to 10 kg in the standard measuring plane. The standard measuring plane is defined as a plane that is within 25 mm of the worktable surface. Depending on load distribution, accuracy at maximum payload may be less than standard.



Confidence. When Results Matter.™

World Headquarters: Rochester, NY, USA • 585.544.0400 • www.ogpnet.com

OGP Shanghai Co, Ltd: Shanghai, China
86.21.5045.8383/8989 • www.smartscope.com.cn

OGP Messtechnik GmbH: Hofheim-Wallau, Germany
49.6122.9968.0 • www.ogpmesstechnik.de

Optical Gaging (S) Pte Ltd: Singapore • 65.6741.8880 • www.smartscope.com.sg